



A Tsurumi Pump Company

PRODUCT DATA SHEET

DGG VORTEX

ZEN-DGG300/2/80HG0ETEX | 807392



IMAGE INDICATIVE ONLY

PRODUCT DETAILS

The DGG is a cast-iron, submersible vortex pump designed for the transfer and lifting of unscreened biological wastewaters containing suspended solids, soft fibrous material, and sewage. Its setback vortex impeller design keeps solids away from the impeller itself, generating flow through hydraulic action rather than direct mechanical contact, providing clog resistance when handling raw, unscreened waste streams.

APPLICATIONS

- Residential and civil sewage lifting – sump pits, basement pump-out, and on-site effluent transfer where raw sewage
- Wastewater treatment plants – transfer of raw influent and biological sludges within treatment processes
- Municipal sewer systems – pump stations handling unscreened sewage
- Livestock and agricultural operations – animal waste slurry transfer and yard washdown effluent
- Light industrial applications – process wastewater containing soft organic solids

FEATURES

- Cast-iron body, impeller and flange EN-GJL250
- AISI 431 motor shaft
- 2-pole, 3-phase motor
- Class H insulation [180°C]
- IP68 protection
- Thermal protections integrated into the stator
- Moisture detection probe fitted to mechanical seal oil chamber
- Two-component epoxy painting 150µm
- Two silicon carbide [SiC] mechanical seals inside the oil chamber
- Cable length 10m

TECHNICAL DATA

RATED POWER P1 / P2	2.8kW / 2.2kW
MAX. FLOW [Q]	13.5 L/sec
MAX. HEAD [M]	8.5 m
MOTOR INSULATION	H Class
PROTECTION CLASS	IP68
MOTOR PROTECTION	Thermal protection and moisture detection
MOTOR DUTY	Continuous Use S1
MAX. LIQUID TEMPERATURE	40°C
MECHANICAL SEAL	Dual Silicon Carbide
MAX. DENSITY AND PH	1.100 kg/m ³ pH 6 – 14

RATED VOLTAGE	400V 3ph 50Hz
MOTOR POLES	2-pole
CURRENT	Rated FLC 4.6A DOL current 28.2A
POWER CABLE TYPE	10m H07RN-F Cable
MAX. HYDRAULIC EFFICIENCY	22.5%
FREE PASSAGE	80 mm
IMPELLER TYPE	Set-back vortex impeller
SUCTION	DN80
OUTLET	DN80
WEIGHT (KG)	44.2 kg (pump only)

CURVE

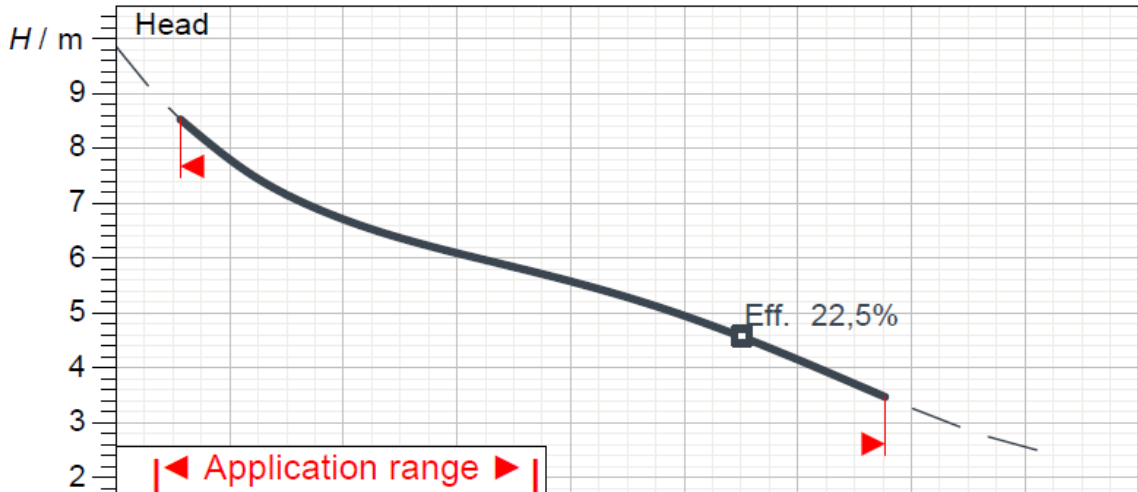

DIMENSIONS

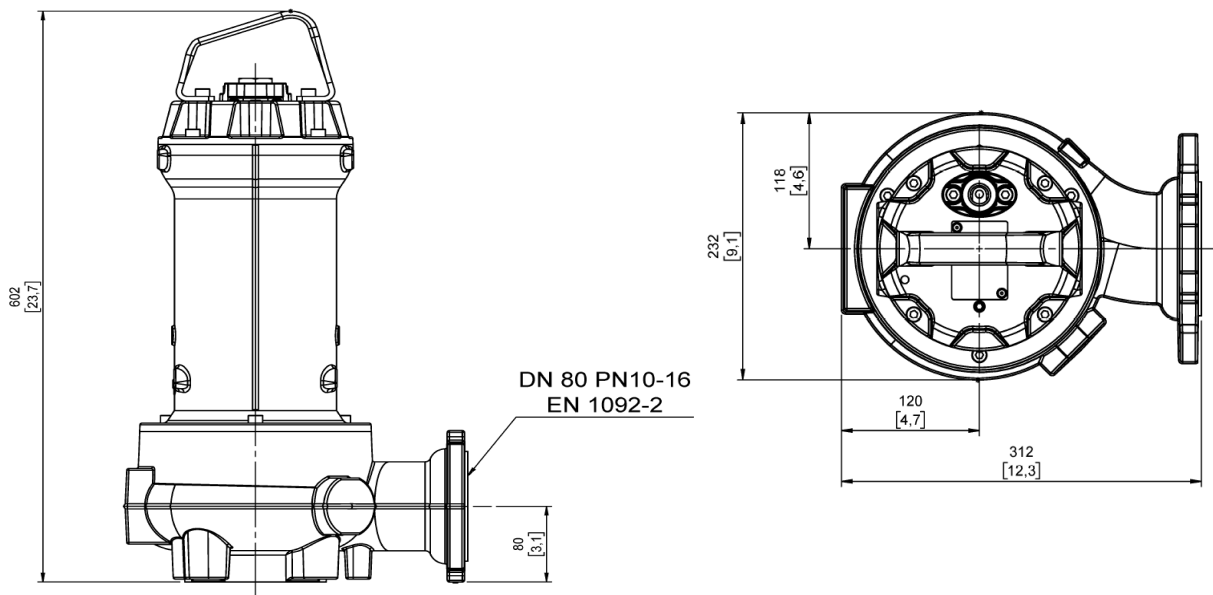

WARRANTY / CERTIFICATIONS

